

CS-PT623 Electronic Pressure Switch

Features

- Relay output
- Over-voltage protected
- Reverse voltage protected
- SS304 casing
- IP65
- The switch head allowed to rotate 330°
- Switch point setting (separately for each)
- OLED display

Applications

- Mechanical
- Industry automatic control
- Pressure measurement for gas and liquid



Description

CS-PT623 is an intelligent pressure switch combining pressure measurement, local display and control together. It uses advanced ARM industrial-grade MCU as core and high quality pressure sensor as sensing element. With well-designation and adjustment, CS-PT623 has quick reaction and good electro-magnetic compatibility for pressure control at the premise of accuracy. It can be widely used for industrial site pressure control in pump, hydraulic and pneumatic equipment. CS-PT623 is able to visually process the process pressure and switch contacts status through switch output, analog output and display screen. It has various output signals for different application. OLED display is very clear to read.

Performance specifications

Temperature: 25°C; power supply: 24VDC; relative humidity: 45%~75%; ambient atmospheric pressure: 86KPa ~ 106KPa

Pressure range	0 ... 0.07 to 0 ... 1000bar
Proof pressure	≥150%F.S
Accuracy at 25°C	±0.5%F.S standard, ±0.25%F.S and ±1%F.S optional, include no-linearity, hysteresis, repeatability, and calibration error
Long-term stability.	±0.25%FS/year
Response Time	≤10ms
Operating Temperature	-20~60°C, but can't beyond the temperature of seal material
Storage Temperature	-20°C ~ 60°C, but can't beyond the temperature of seal material
Output Signal ^{note 1}	4 ~ 20mA and Relay Output

Supply Voltage(U)	24VDC default, allowed 24 ± 5 VDC
Current Output Load	$\leq (U - 12) / 0.023 \Omega$
Relay Output Load	≤ 1000 mA
Overvoltage	32VDC
Reverse Voltage	-30VDC
Insulate Resistance	≥ 100 M Ω @100VDC
IP Rating	IP65
Random Vibration	10g , 5 ~ 2000Hz
Shock	X/Y/Z, 20g, sine 11ms
Pressure connector	G1/2, G1/4, M20*1.5, NPT1/2, NPT1/4 and others
connector material	304 stain steel default, 316L stain steel and Titanium optional
Electrical connection	M12 \times 1-5P
Seal material	NBR O-Ring default (-20 $^{\circ}$ C ~ +100 $^{\circ}$ C), FKM optional (-15 $^{\circ}$ C ~ +135 $^{\circ}$ C) or others

Dimensions (mm)

M12-5P



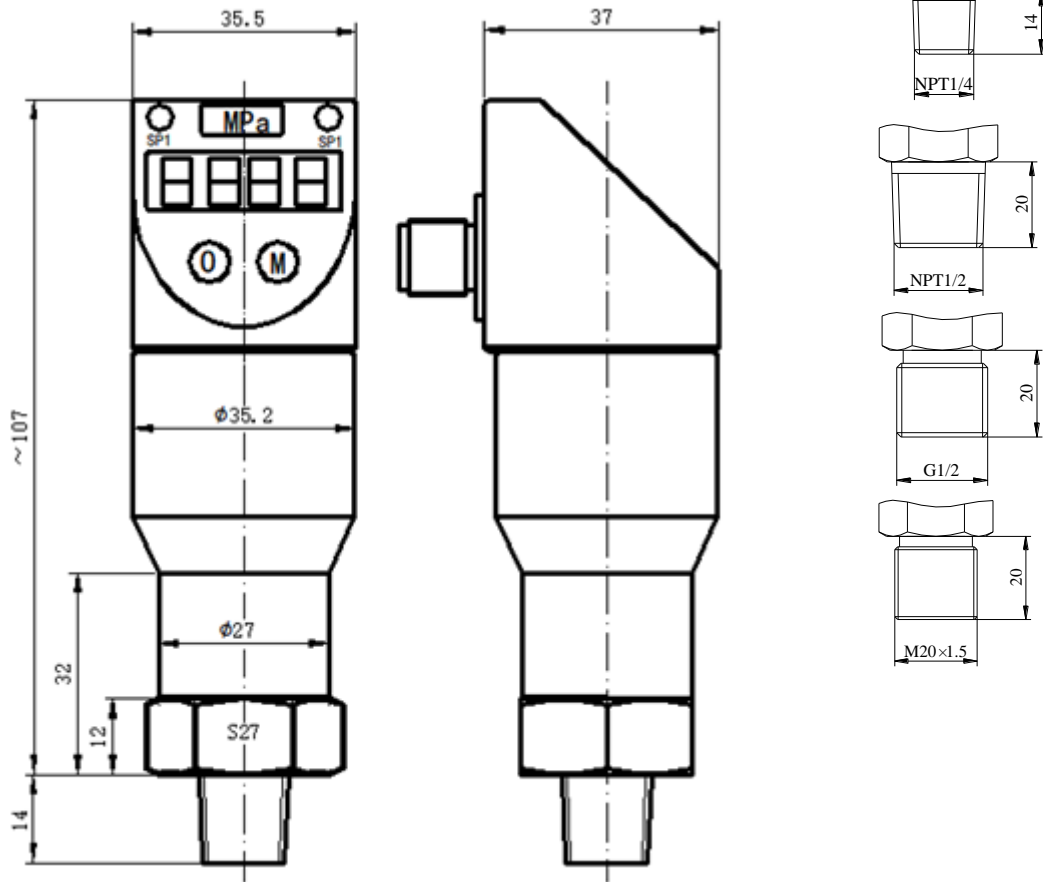

Electrical Connection

Pin	Define	Color
1	VCC	Brown
2	Alarm Port A1	White
3	GND	Blue
4	Alarm Port A2	Black
5	4~20mA Output	Gray

Schematic Diagram

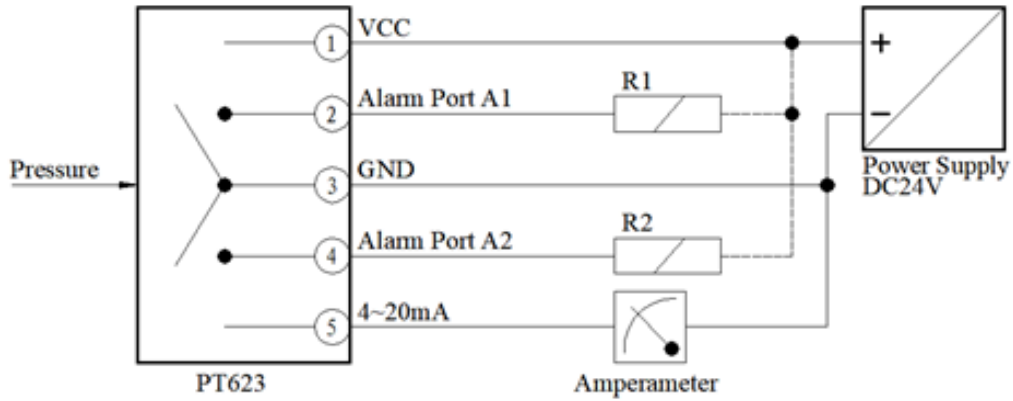

The load R1 (or R2) should be connected between the alarm port A1 (or A2) and VCC port. The action pressure of each alarm port can be set separately.

★To make the pressure switch working well, the current output (port 5, 4~20mA) must be connected to GND or a current measuring port.

Switching Mode

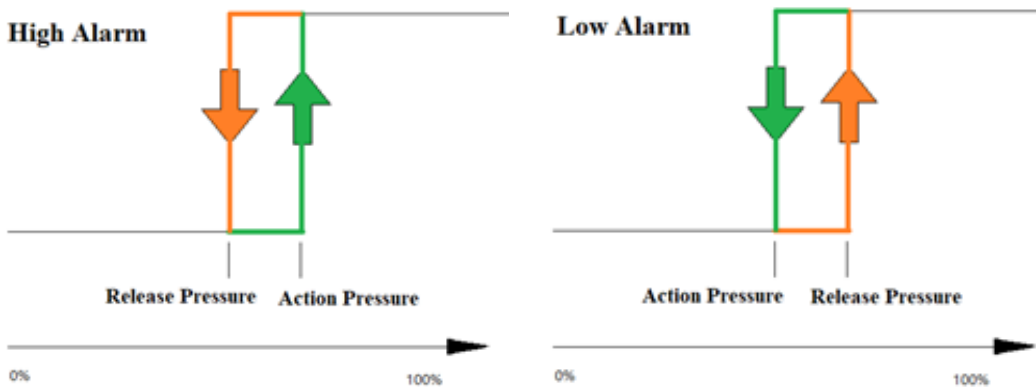

$$\text{Return Stroke Error} = | \text{Action Pressure} - \text{Release Pressure} |$$

Adjust

See the *CS-PT623 Menu Instruction.pdf*.

Type Selected

PT623	Electronic Pressure Switch
Mark	Pressure Range
X	Actual Pressure Range
Mark	Pressure Connection
G1/2	G1/2
G1/4	G1/4
M20×1.5	M20×1.5

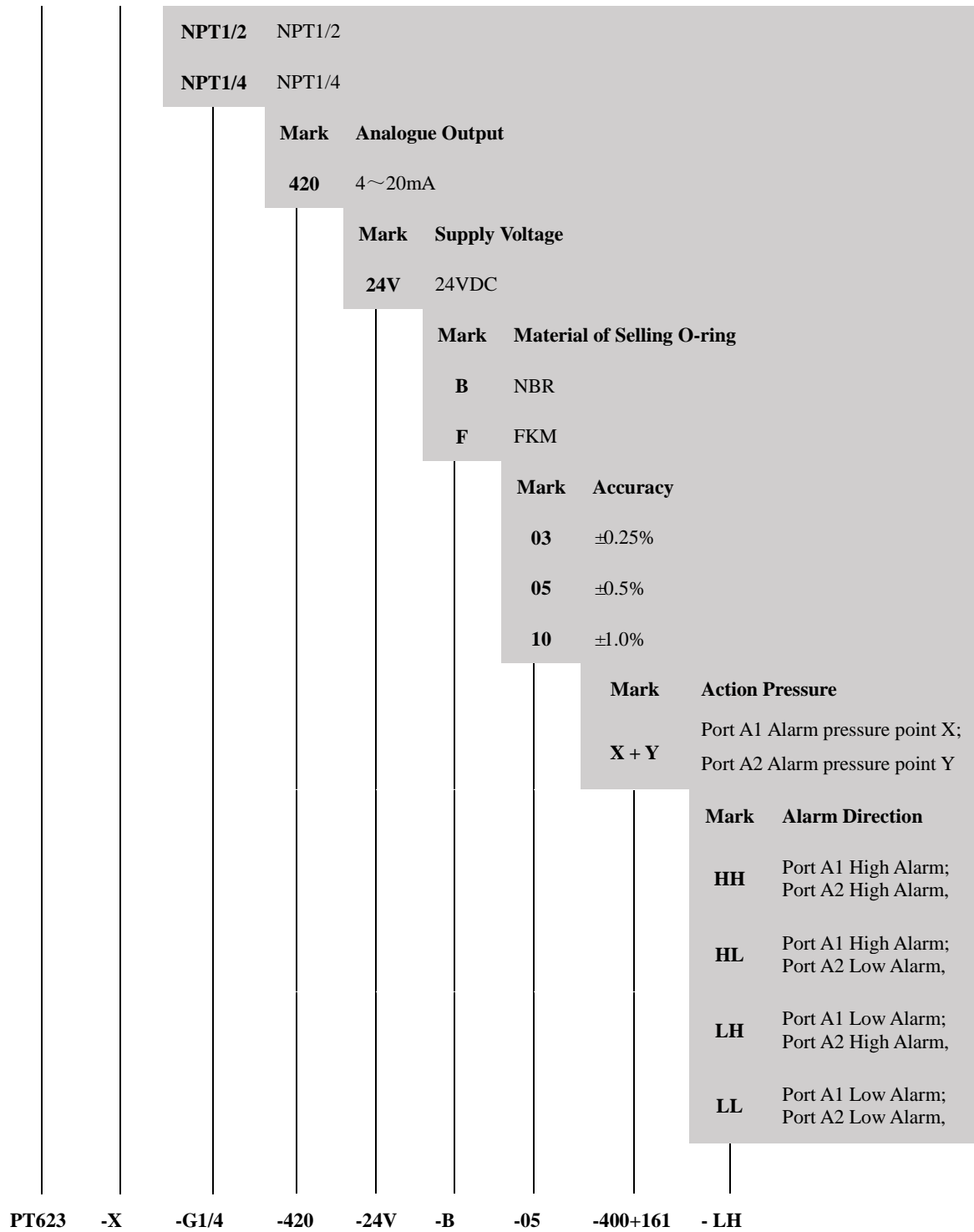

For example: CS-PT623-201-G1/4-M12 (5)-420-16-B-05-400+161-LH means:

CS-PT623 Electronic Pressure Switch,

Pressure Range (201): 0~2bar (200kPa),

Pressure Port (G1/4): G1/4,

Analogue Output(420): 4~20mA,

Supply Voltage(24V): 24VDC,

Material of Selling O-ring(B): NBR,

Accuracy(05):	±0.5%,
Action Pressure(400+161):	Action pressure of alarm port 1 is 0.4bar (it is under costumer's order, or 20% of pressure range as default), Action pressure of alarm port 2 is 1.6bar (it is under costumer's order, or 80% of pressure range as default),
Action Direction (LH):	Alarm port 1 outputs when the pressure below its action pressure (it is under costumer's order, or low alarm as default), Alarm port 2 outputs when the pressure above its action pressure (it is under costumer's order, or high alarm as default),
Electrical Connection:	M12×1-5P default.

Notes

1. Only use the pressure switch to test the medium which have no corrosion to its housing and seal material.
2. Cannot use sharp tools to clean the pressure hole when the hole of the pressure switch is blocked. The pressure switch shall be removed from system and put the pressure hole part into the fluid which can dissolve the blocking substance.
3. The switch should be installed in locations where they are not easily to be impacted or trampled.
4. Use beyond the overload pressure of the switch may cause damages.
5. In order to protect the transmitter used at areas with many lightning, suggest adding a lightning protection device and reliably connecting the shield line to EARTH.
6. Please contact factory for other needs.

Statement

Xi'an Chinastar M&C Limited reserves the right to modify the specifications and contents of this instruction. No further notice will be given if any changes are made. Due to product updates, the individual details of this document may not match the product. Please refer to the actual product. The right to interpret this document belongs to Xi'an Chinastar M&C Limited.
